

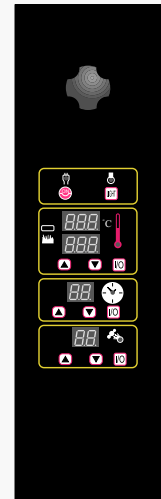

These ovens are constructed of stainless steel, and include steam and stone sole for the traditional baker who has an eye for detail. The temperature can be adjusted via the digital controls for both under sole heating and top heat distribution. This oven has steam injection as opposed to water spray, offering a much higher quality of steam, giving

you an even higher lift and better quality crust. To minimise the risk of steam burns during baking, the double glazed glass doors open downwards. They offer independent control to lower and increase temperatures, giving you two desired set points, allowing greater flexibility.

Convection ovens are fitted with the ability to take New Zealand 16" and 18" standard trays simultaneously. The airflow is distributed to provide an even bake across the tray, by alternating the direction on a timed basis, so that there are reduced static areas in the chamber. The interior of the oven is constructed of stainless steel, including a stainless steel fan. All of our ovens have digitally controlled temperature, bake time, and steam time. Many different configurations are available, as our system is modular. For example, a prover can be added at a later stage.

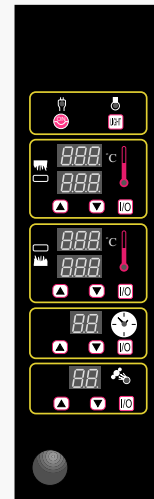

ESM-93X Series	
Per Deck	
Capacity	
Tray Size	460mm x 760mm
Tray Capacity	3
Electrical Requirements	
Power	11kW
Voltage	415V
Phases	3, Neutral + Earth
Frequency	50Hz
Fuse	63A per phase
Connection	Hard Wired
Dimensions	
Width	1940mm
Depth	1155mm
Height	460mm
Crown Height	230mm
Per Unit	
Hood Dimensions	
Width	1940mm
Depth	1400mm
Height	380mm
Stand Dimensions	
Width	Varies Between Models- Please Contact Us
Depth	
Height	

ESM-94X Series	
Per Deck	
Capacity	
Tray Size	460mm x 760mm
Tray Capacity	4
Electrical Requirements	
Power	11kW
Voltage	415V
Phases	3, Neutral + Earth
Frequency	50Hz
Fuse	63A per phase
Connection	Hard Wired
Dimensions	
Width	2140mm
Depth	1155mm
Height	460mm
Crown Height	230mm
Per Unit	
Hood Dimensions	
Width	2140mm
Depth	1400mm
Height	380mm
Stand Dimensions	
Width	Varies Between Models- Please Contact Us
Depth	
Height	

ESM-705E Convection Oven	
Oven Capacity	
Tray Size	460mm x 760mm
Tray Capacity	5
Prover Capacity	
Tray Size	460mm x 760mm
Tray Capacity	10
Oven Electrical Requirements	
Power	12.5kW
Voltage	400V
Phases	3, Neutral + Earth
Frequency	50Hz
Fuse	20A per phase
Connection	4-Pin PDL 56 PA 420
Prover Electrical Requirements	
Power	1kW
Voltage	400V
Phases	3, Neutral + Earth
Frequency	50Hz
Fuse	20A per phase
Dimensions	
Width	890mm
Depth	1600mm
Height	1950mm

ESM-710E Convection Oven	
Oven Capacity	
Tray Size	460mm x 760mm
Tray Capacity	10
Prover Capacity	
Tray Size	460mm x 760mm
Tray Capacity	10
Oven Electrical Requirements	
Power	25kW
Voltage	400V
Phases	3, Neutral + Earth
Frequency	50Hz
Fuse	36A per phase
Connection	4-Pin PDL 56 PA 440
Prover Electrical Requirements	
Power	1kW
Voltage	400V
Phases	3, Neutral + Earth
Frequency	50Hz
Fuse	20A per phase
Dimensions	
Width	890mm
Depth	1600mm
Height	2510mm

Ovens

BAKERY SERVICES

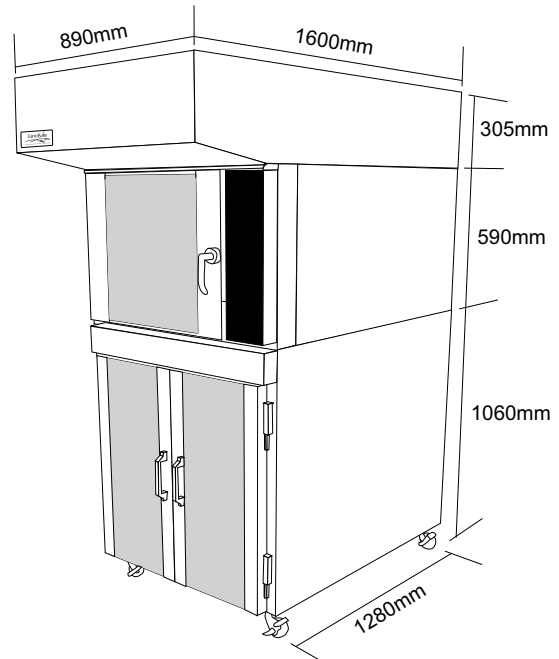
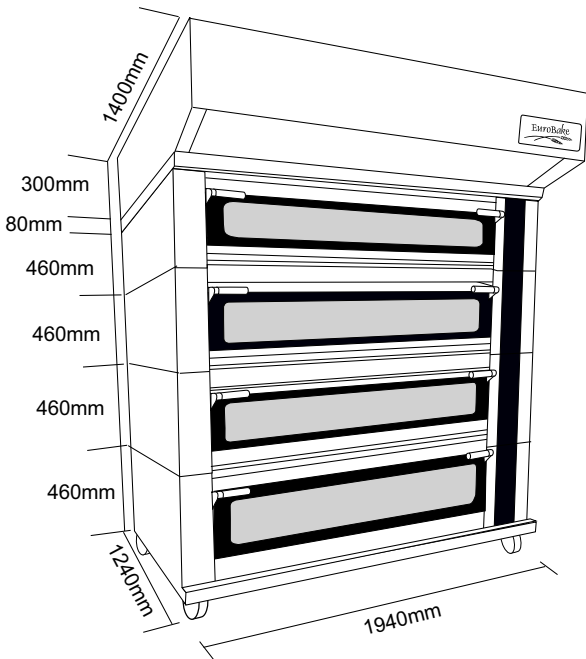
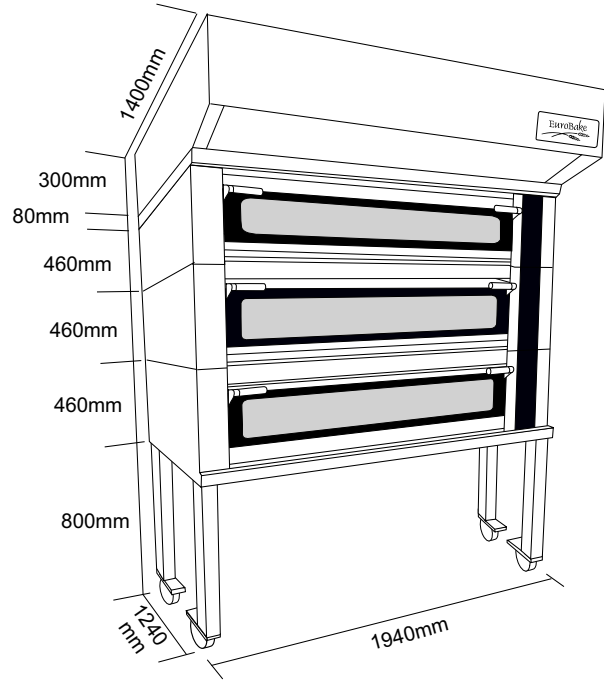
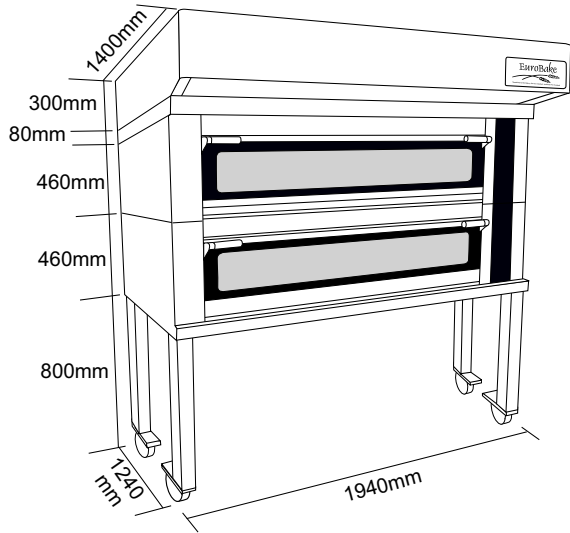

BAKERY SERVICES LIMITED

Auckland Branch
 11 Civil Place
 Albany 0632
 PO Box 101-999
 North Shore Mail Centre
 Auckland
Phone: 09 478 2445
Fax: 09 478 2145

Wellington Branch
 5/49 Kenepuru Drive
 Porirua 6006
 PO Box 50-185
 Porirua 6215
 Wellington
Phone: 04 238 9300
Fax: 04 238 9301

www.bakeryservices.co.nz - info@bakeryservices.co.nz

Notes: All shown deck ovens are 3 tray models